



Say yes to solar power! Because it protects the climate.

Innovations from a photovoltaic pioneer

As a solar specialist with 50 years' experience in photovoltaics (PV), Sharp makes significant contributions to ground-breaking progress in solar technology.

Sharp photovoltaic modules in the ND series are designed for applications with high power requirements. These quality polycrystalline modules produce a continuous, reliable yield, even under demanding operational conditions.

All Sharp ND series modules offer system integration which is optimal both technically and economically, and are suitable for installations in on and off-grid PV systems.



Brief details for the installer

- 156.5 mm × 156.5 mm polycrystalline solar cells
- 60 cells in series
- 2,400 N/m² mechanical load-bearing capacity (245 kg/m²)
- 1,000 V DC maximum system voltage
- IEC/EN 61215, IEC/EN 61730, Application class A
- Class II (VDE: 40021391)

Product features

- High-performance photovoltaic modules made of polycrystalline (156.5 mm)² silicon solar cells with module efficiencies of up to 14.0 %.
- 3 busbar technology for enhancing the power output.
- Bypass diodes which minimise the loss in output when shading occurs.
- Textured cell surface for particularly high electricity yields.
- BSF structure (Back Surface Field) to optimise cell efficiency.
- Use of tempered white glass, EVA plastic, and weather protection film, as well as an anodised aluminium frame with drainage outlets for long-term use.
- Output: connection cable with waterproof plug connector.

Quality from Sharp

Benchmarks are set by the quality standards of Sharp Solar. Continual checks guarantee a consistently high level of quality. Every module undergoes visual, mechanical, and electrical inspection. This is recognisable by means of the original Sharp label, the serial number, and the Sharp guarantee:

- 5 year product guarantee
- 10 year performance guarantee for a power output of 90%
- 25 year performance guarantee for a power output of 80%

The detailed guarantee conditions and additional information can be found at www.sharp.eu.

Mechanical data	
Cell	Polycrystalline (156.5 mm) ² silicon solar cells
Quantity and wiring of cells	60 in series
Dimensions	1,652 × 994 × 46 mm (1.64 m ²)
Weight	19 kg
Connection type	Cable with plug connector (MC-3)

Limit values		
Operating temperature (cell)	-40 to +90	°C
Storage temperature		
Storage air humidity (relative)	up to 90	%
Maximum system voltage	1,000	V DC
Maximum mechanical load	2,400	N/m ²
Over-current protection	15	A

Electrical data		ND-E230 (A2)	ND-E220 (A2)	ND-E210 (A2)	
Maximum power	P_{max}	230 W _p	220 W _p	210 W _p	
Open-circuit voltage	V_{oc}	37.0	36.8	36.6	V
Short-circuit current	I_{sc}	8.24	7.96	7.68	A
Voltage at point of maximum power	V_{mpp}	30.3	30.2	30.1	V
Current at point of maximum power	I_{mpp}	7.60	7.29	6.98	A
Module efficiency	η_m	14.0	13.4	12.8	%
NOCT		47.5	47.5	47.5	°C
Temperature coefficient – open-circuit voltage	αV_{oc}	-130	-130	-130	mV / °C
Temperature coefficient – short-circuit current	αI_{sc}	+0.053	+0.053	+0.053	% / °C
Temperature coefficient – power	αP_{max}	-0.485	-0.485	-0.485	% / °C

The electrical data applies under standard test conditions (STCs): irradiation 1,000 W/m² with light spectrum AM 1.5 and a cell temperature of 25 °C. The rated electrical characteristics are subject to a manufacturing tolerance of -5% / +10%. NOCT conditions: irradiation of 800 W/m², ambient temperature of 20 °C and wind speed of 1 m/sec.

Characteristic curves ND-E230 (A2)

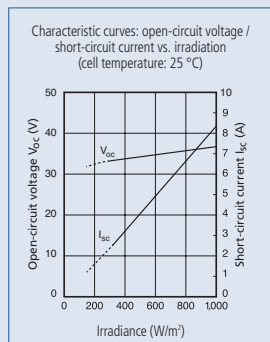
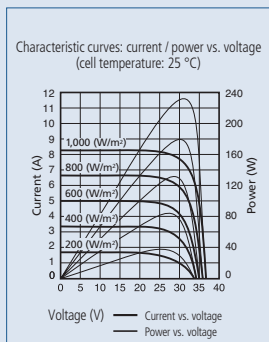

Applications

- On-grid PV systems
 - On-roof PV systems
 - Off-grid PV systems
 - Ground-mounted PV systems
- Please read our detailed installation manual carefully before installing the photovoltaic modules.

Registration

Sharp Solar guarantees safety, product quality and value stability for many years – the only thing we ask is: that you register your modules with the serial numbers so we can send you the warranty certificate. It is quick and easy to register your modules at www.brandaddedvalue.net

Exterior dimensions

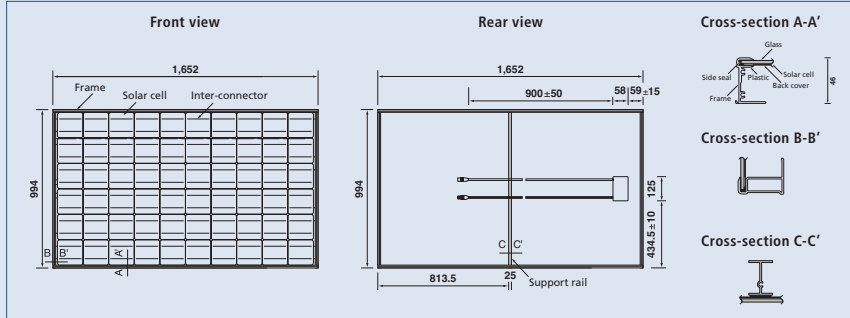

Note

Technical data is subject to change without prior notice. Before using Sharp products, please request the latest data sheets from Sharp. Sharp accepts no responsibility for damage to devices which have been equipped with Sharp products on the basis of unverified information.

The specifications may deviate slightly and are not guaranteed. Installation and operating instructions are to be found in the corresponding handbooks, or can be downloaded from www.sharp.eu.

This module should not be directly connected to a load.

Sharp Energy Solution Europe
a division of Sharp Electronics (Europe) GmbH
Sonninstrasse 3, 20997 Hamburg, Germany
Tel: +49 (0) 40 / 23 76 - 0 • Fax: +49 (0) 40 / 23 76 - 21 93
www.sharp.eu

Local responsibility:

Austria
SolarInfo.at@sharp.eu
Benelux
SolarInfo.seb@sharp.eu
Central & Eastern Europe
SolarInfo.scee@sharp.eu

Denmark
SolarInfo.dk@sharp.eu
France
SolarInfo.fr@sharp.eu
Germany
SolarInfo.de@sharp.eu

Scandinavia
SolarInfo.sen@sharp.eu
Spain & Portugal
SolarInfo.es@sharp.eu
Switzerland
SolarInfo.ch@sharp.eu
United Kingdom
SolarInfo.uk@sharp.eu

